

INTELLIVOX DDC



Security Systems

EN | Installation Manual
Active Line Array Loudspeakers
LBC 325x Series

BOSCH

Disclaimer

1. The information in this manual has been carefully checked for accuracy, but no guarantee is given as to the correctness.
2. The information in this manual is subject to change without notice, and does not represent a commitment on the part of the vendor. Bosch Security Systems shall not be liable for any loss or damage whatsoever arising from the use of information or any error contained in this manual.
3. No part of this manual may be reproduced, stored in a retrieval system, or transmitted, in any form or by any means, electronic, electrical, mechanical, optical, chemical, including photocopying and recording, for any purpose other than the purchaser's personal use without the express written permission of Bosch Security Systems.
4. The unit is designed to operate from AC 50/60 Hz, 115V or 230 V - please, see the label on the unit. Never connect to any other voltage or frequency.
5. Unplug the product before cleaning. Do not use liquid cleaners or aerosol cleaners but a damp cloth.
6. Protect the product from overheating. Do not block ventilation slots. The product should not be built-in unless proper ventilation is provided.
7. The purchaser should not attempt to service the product, as he or she may be exposed to dangerous voltages. All maintenance and service should be carried out by Bosch Security Systems or its authorized agents. Bosch Security Systems cannot accept any liability for any loss or damage caused by service, maintenance or repair by unauthorized personnel.

Table of contents

1.	INTRODUCTION.5
2.	INSTALLATION GUIDE.6
2.1	ITEMS IN THE BOX.6
2.2	GENERAL CONSIDERATIONS.6
2.3	WIRING AND CONNECTIONS.8
2.3.1	Mains power.8
2.4	SIGNAL CONNECTIONS.8
2.5	METHODS FOR MOUNTING THE INTELLIVOX.10
2.5.1	General.10
2.5.2	Measures and dimensions.11
2.5.3	Mounting procedure.12
3.	APPENDIX.13
3.1	REFERENCE PART LIST.13
3.2	GROUNDING STRATEGY.13
3.3	SOME NOTES ON THE RS-485 NETWORK INTERFACE.17
3.4	AMBIENT SPL AND TEMPERATURE SENSOR.20
3.5	INTELLIVOX DIMENSIONS OF THE DIFFERENT MODELS.22

Figure and Table lists.

Fig 1	LBC 3253/00 Intellivox-2c shown without front grill.	5
Fig 2	WAGO massive to stranded wire clamp.	8
Fig 3	Intellivox connector block.	9
Fig 4	WAGO 231 cross-section.	10
Fig 5	Connecting a WAGO 231.	10
Fig 6	Standard Intellivox wall bracket, all dimensions in mm.	10
Fig 7	LBC 3253/00 Intellivox-2c dimensions, all measures in mm.	11
Fig 8	Ground configuration of the Intellivox chassis.	14
Fig 9	Standard grounding configuration.	14
Fig 10	Grounding configuration with totally decoupled audio ground.	15
Fig 11	Grounding configuration with low frequency decoupled audio ground.	15
Fig 12	Ground configuration with audio ground partly decoupled for low frequencies. ..	16
Fig 13	Optional high frequency decoupling for 70 V / 100 V systems.	17
Fig 14	Structure of the RS-485 network.	17
Fig 15	Connection of twin twisted network cable to the unit.	18
Fig 16	Wiring configuration using asymmetrical cable type.	20
Fig 17	Wiring configuration using RS-485 network cable type.	21
Fig 18	Wiring configuration at the sensor using asymmetrical cable type.	21
Fig 19	Wiring configuration at the sensor using RS-485 network cable type.	21
Fig 20	LBC 3251/00 Intellivox-1b dimensions, all measures in mm.	22
Fig 21	LBC 3252/00 Intellivox-2b dimensions, all measures in mm.	23
Fig 22	LBC 3252/10 Intellivox-2b dimensions, all measures in mm.	24
Fig 23	LBC 3253/00 Intellivox-2c dimensions, all measures in mm.	25
Fig 24	LBC 3253/10 Intellivox-2c dimensions, all measures in mm.	26
Fig 25	LBC 3254/00 Intellivox-4c dimensions, all measures in mm.	27
Fig 26	LBC 3254/10 Intellivox-4c dimensions, all measures in mm.	28
Fig 27	LBC 3256/00 Intellivox-6c dimensions, all measures in mm.	29
Fig 28	LBC 3256/10 Intellivox-6c dimensions, all measures in mm.	30

1. Introduction.

This paper describes the factory recommended installation procedure for the Bosch Security Systems' Intellivox range of controlled loudspeaker-arrays.

This type of loudspeaker-array is equipped with an on-board Digital Signal Processor (DSP) module. This manual describes mechanical matters like mounting hole positions and outlets for cable feed-through, as well as information for wiring of the connectors.

A very important parameter is the mounting height. This parameter can be very confusing, because during the acoustical design process the height of the acoustically active part of the column is optimized, while during installation the issue of interest is the physical mounting height of the column. Unfortunately there is no fixed relation between these two, because the exact position of the acoustical part of the array inside the enclosure is depending on the location of the electronics module. In the standard LBC 325x/00 versions of the Intellivox, the electronics module is mounted in the lower end of the enclosure (as it is shown in Fig 1). The LBC 325x/10 versions however, have the electronics module mounted at the top end.

Because of the extreme tight vertical radiation pattern of the Intellivox, a small deviation from the calculated acoustical mounting height may cause severe degradation of the expected performance.

For this reason the designer is advised to define two mounting heights, a physical mounting height which refers to the physical bottom side of the enclosure, and an acoustical mounting height, referring to the on-axis location of the loudspeaker at the lowest position.

Although the physical mounting positions are of primary concern to the contractor, a quick check of the acoustical height during installation will confirm the integrity of the original acoustical design.

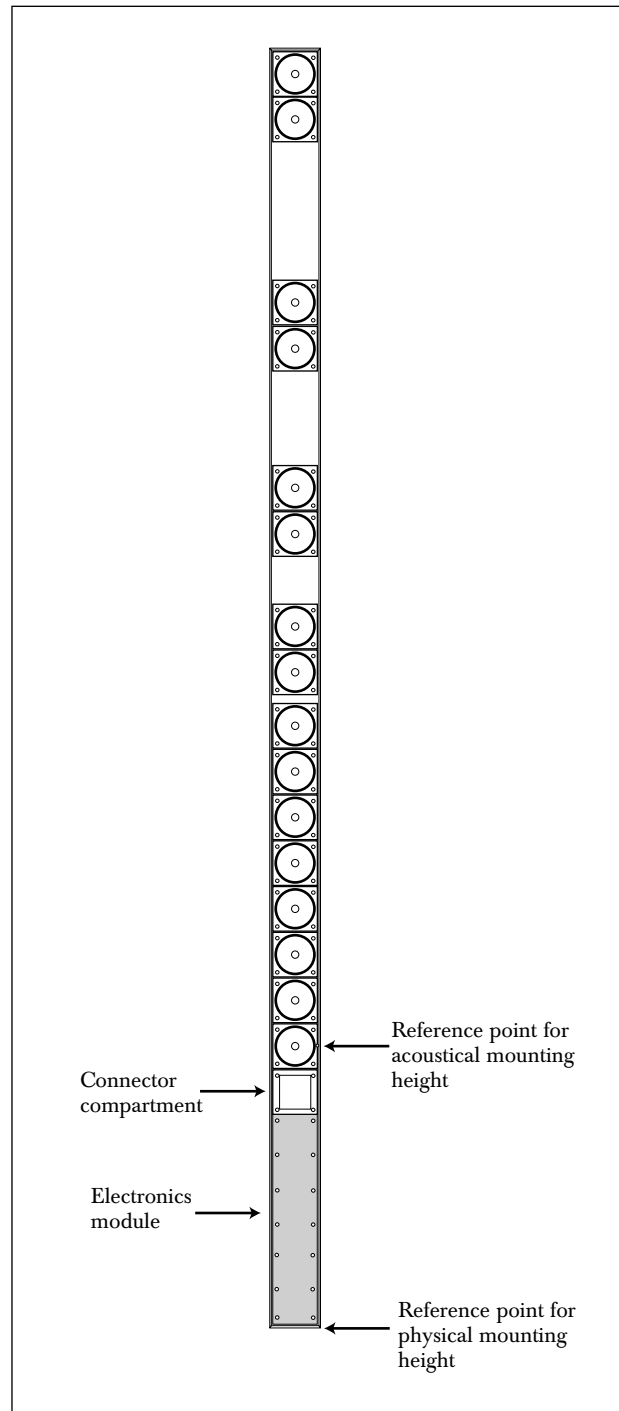

Fig 1 Intellivox-2c shown without front grill.

2. Installation guide

This chapter deals with the practical aspects of installing the Intellivox loudspeaker column.

- SI units are used as a default, all mentioned dimensions are stated in meters or millimeters.
- Unless stated otherwise, column dimensions refer to the standard Intellivox-2c, which has the electronics module mounted at the low end of the enclosure. Dimensions of other Intellivox models can be taken from the appropriate datasheet.

2.1 Items in the box.

The following items are shipped with each Intellivox column:

Description	Pieces
Mounting brackets	2
IEC 3p female mains connector (cable socket)	1
WAGO series 231 6p input signal connector (cable socket with strain relief housing)	1
WAGO series 231 5p RS485 signal connector (cable socket with strain relief housing)	1
PVC inserts for WAGO connectors (for 3 different wire sizes)	1 x 5 2 x 2 x 5
Wire insertion tool for WAGO cage clamp connector	1

Table 1 List of shipped items.

- The mounting brackets as well as the connector set are packed in one of the top end boxes of the main packaging.

2.2 General considerations.

As already mentioned, mounting height and position are important parameters in relation to the acoustical performance of the system. Unless specified otherwise by the sound system designer, the Intellivox column should be mounted in a position exactly perpendicular to the listening plane. Contrary to a conventional 'low Q' loudspeaker system, minor mechanical misalignment may lead to a degraded coverage and intelligibility.

Unless otherwise stated by the designer, the Intellivox column with a-symmetrically placed transducers, should be mounted with the 'high frequency acoustical center' at the lowest position.

The Intellivox is mains powered, the mains ground terminal should always be connected to a proper safety ground. Other safety regulations may also require a separate mains distribution network or an uninterruptible mains power supply (UPS).

The Intellivox requires a signal source. For this purpose preferably a symmetrical line level (0 dBV) signal can be used. Alternatively the audio input can be supplied by an existing 70V/100V network (if the default transformer balanced input board is installed). Refer to chapter 3.2 and chapter 2.4 for more information.

The Intellivox is equipped with a RS-485 network interface. This interface serves two basic purposes. The first one is to adjust all relevant parameters (i.e. gain, 'steering' angle) during installation. Secondly it might be used to integrate the Intellivox into a network for continuous surveillance and 'on line' control. In cases where these last mentioned network options are not required, the RS-485 wiring can be omitted. One should however realize that the existence of network wiring greatly simplifies the transfer of the initial parameters as well as any future DSP software upgrades or functional check-ups, especially in situations where a unit is located on a position which is hardly accessible. Refer to chapter 3.3 for more information about the RS-485 network.

If more than one unit has to be connected to the RS-485 network, make sure that every unit is set to a unique network address before connecting to the RS-485 network. The network address can be changed by connecting the individual device via an RS-232 to RS-485 adapter to a host PC running WinControl the appropriate software. More information can be found in the help file of WinControl.

A simple surveillance function may be realized by means of the 'failure detect' connection in case the RS-485 network interface is not used. Three relay contacts, 'normally open' (NO), 'normally closed' (NC) and 'common' (COM) are available on this connector.

If the autogain function of the Intellivox is used, a separate ambient SPL/temperature sensor has to be installed and connected. This automatic volume adaptation feature will only function properly if the signal, which is detected by the microphone inside the sensor, is representative for the diffuse ambient noise level. For this reason the sensor should be kept away from direct sound sources such as talking people, outlets of the air conditioning system or other loudspeakers. The implemented software protocol freezes the volume setting when an audio signal is present in order to prevent 'hunting' of the column's gain setting caused by its own acoustical output. All relevant autogain parameters can be adjusted by means of the RS-485 interface. In practice, the most favorable sensor locations are walls or ceilings (height > 3 m) within a range of 25 m of the corresponding Intellivox (see also chapter 3.4).

If the ambient temperature is expected to exceed 40°C an external fan should be connected to ensure proper operation of the Intellivox under all circumstances. For this purpose an external 24 V relay should be connected to the terminal block marked 'Fan Relay'. Because of the limited drive current an external relay must always be used to switch the fan, do not connect a fan directly to this terminal! The external relay (if connected) will be engaged if the heatsink temperature exceeds the threshold. The fan should be mounted on a location ensuring sufficient airflow along the heatsink.

In case the Intellivox is installed outside or in another environment with a high expected humidity, the electronics should be treated with an insulation substance to prevent defects due to condensing moisture. If specially ordered, this can be done during the manufacturing process.

To prevent damage to the loudspeakers due to frozen moisture inside the voice-coil gap, each Intellivox is equipped with a 'frost protection'. If the ambient temperature drops below a certain threshold the internally generated pilot tone for the frost protection will be activated. The aforementioned ambient SPL/temperature sensor should be installed for this function to operate properly. The switching threshold and hysteresis can be adjusted through the RS-485 interface.

2.3 Wiring and connections.

2.3.1 Mains power.

- Be sure that the mains voltage stated on the unit complies with the local standard before connecting the Intellivox to the mains supply.

The maximum power consumption of the Intellivox-2c model is 450 VA, this figure however is different from other models (refer to the appropriate datasheet). The Intellivox is equipped with a 3-pin IEC type mains inlet / fuse holder. If the fuse needs to be replaced only replace with the same value. The IEC cable socket which is supplied with the unit is only suited for use with stranded wires. The preferred (and most straightforward) solution is to feed the Intellivox from a mains power outlet situated nearby the unit using an 'off the shelf' $3 \times 0.75 \text{ mm}^2$ (AWG 18) IEC mains cable. If the mains outlet is located directly behind the Intellivox it should be recessed to be able to mount the unit flat to the wall.

In case it is necessary to make a connection from massive to stranded wires, the use of an appropriate clamp is advised. A cross-sectional view of such a clamp construction is shown in Fig 2. Refer to chapter 3.1 for ordering info.

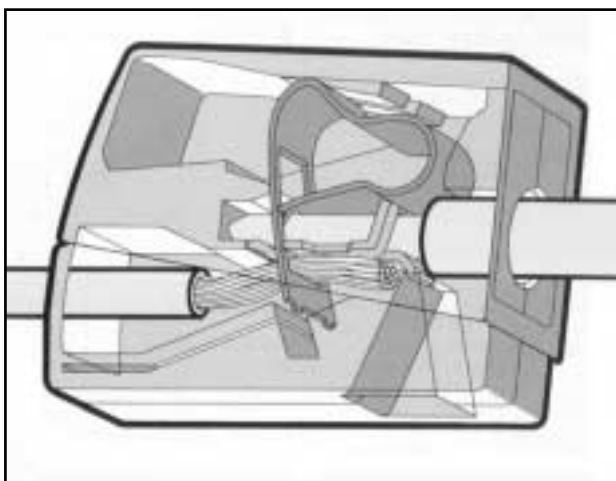

Fig 2 WAGO massive to stranded wire clamp.

2.4 Signal connections.

All signal connections are realized by using WAGO series 231 cage clamp connectors. A major advantage of these connectors is the fact that the connector can be fitted without the need for soldering. The connectors can be used with 0.08 mm^2 (AWG 28) to 2.5 mm^2 (AWG 12) wires, both stranded or massive.

The audio and RS-485 signal cable socket is supplied with the Intellivox. Also three different sized PVC inserts are supplied which can be inserted in the connector if small wire sizes are used (usually for the audio line input connection). The connector for the SPL/temperature measurement is supplied with the corresponding sensor. This sensor has to be ordered separately. Refer to chapter 3.1 for ordering information if the installation requires extra connectors.

The preferred cable types and the connector pin configuration is extensively discussed in chapters 3.2 and 3.3. All connectors are located in the Intellivox connector compartment which is accessible from the rear and front side of the column (except Intellivox-1b which is only accessible from the rear). A drawing of the connector block is shown in Fig 3. A figure similar to Fig 3 (right side) can be found at the rear side of the panel that covers the connector compartment.

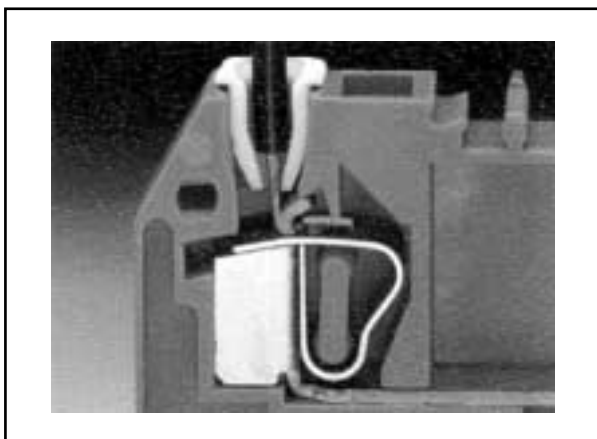

Fig 4 WAGO 231 cross-section

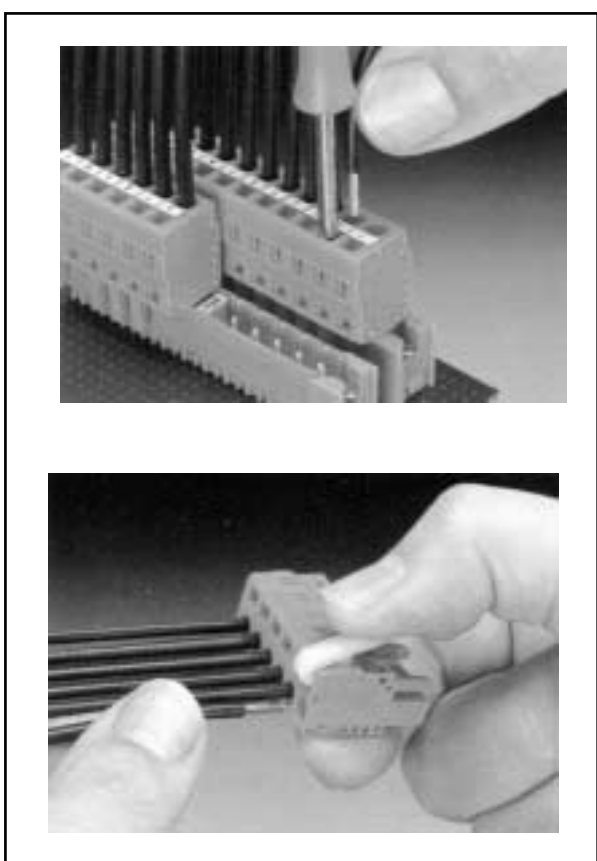

Fig 5 Connecting a WAGO 231

Description	Wire size
White PVC insert	0.08 - 0.2 mm ²
Light gray PVC insert	0.25 - 0.5 mm ²
Dark gray PVC insert	0.75 - 1.0 mm ²

Table 2 PVC insert sizes.

2.5 Methods for mounting the Intellivox.

2.5.1 General.

For mounting of the Intellivox column there are two or three attachment points (depending on the model) each consisting of four threaded inserts at the rear of the enclosure. One point is located at the upper side, the other near the bottom and the third, if existing, at the center position. The column should be mounted using both locations. All threaded inserts are M5 metric and should only be used with the appropriate screws which are supplied with the original mounting hardware.

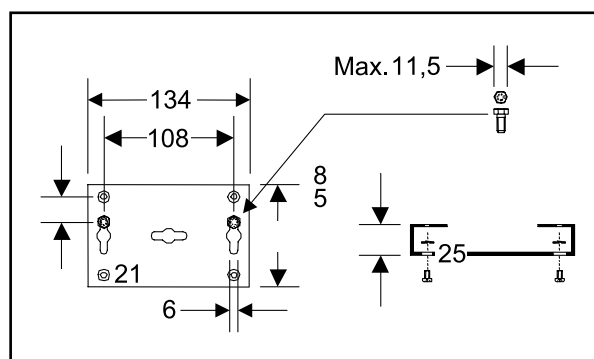

Fig 6 Standard Intellivox wall bracket, all dimensions in mm.

There are three options for mounting the Intellivox column.

1. The first (and most often used) mounting method of the Intellivox is by means of two or three (depending on the model) identical wall brackets. The brackets are supplied with each Intellivox and come in the same color as the enclosure. A technical drawing of the bracket is shown in Fig 6. The brackets allow mounting of the Intellivox on a straight wall or on a curved surface (pillar) while keeping a distance of 25 mm (1.0") between the rear of the enclosure and the wall. Refer to chapter 2.5.3 for the standard mounting procedure details.
2. A second method is to mount the Intellivox using swivel brackets which allow the column to be positioned in a certain horizontal angle with respect to the wall. In this case two or three (depending on the model) swivel brackets are needed, one on the top side and one at the bottom and one in the center position if applicable. The horizontal angle of the swivel brackets can be secured by the

hexagonal nut. The swivel brackets are mounted to the rear of the enclosure by four M5 pan head screws (factory supplied). Refer to Table 4 in chapter 3.1 for ordering information.

3. The third method is to mount the column directly to a wall or a dedicated mounting panel by means of spacers and screws through the mounting surface. In this case extra attention should be paid to the following aspects:

- The threaded inserts are M5 metric and the depth is 16 mm.
- It is advised to keep the rear side of the Intellivox free from the wall in order to prevent unwanted resonances.

2.5.2. Measures and dimensions.

As mentioned earlier all enclosure dimensions refer to the Intellivox-2c. Other models or custom supplied

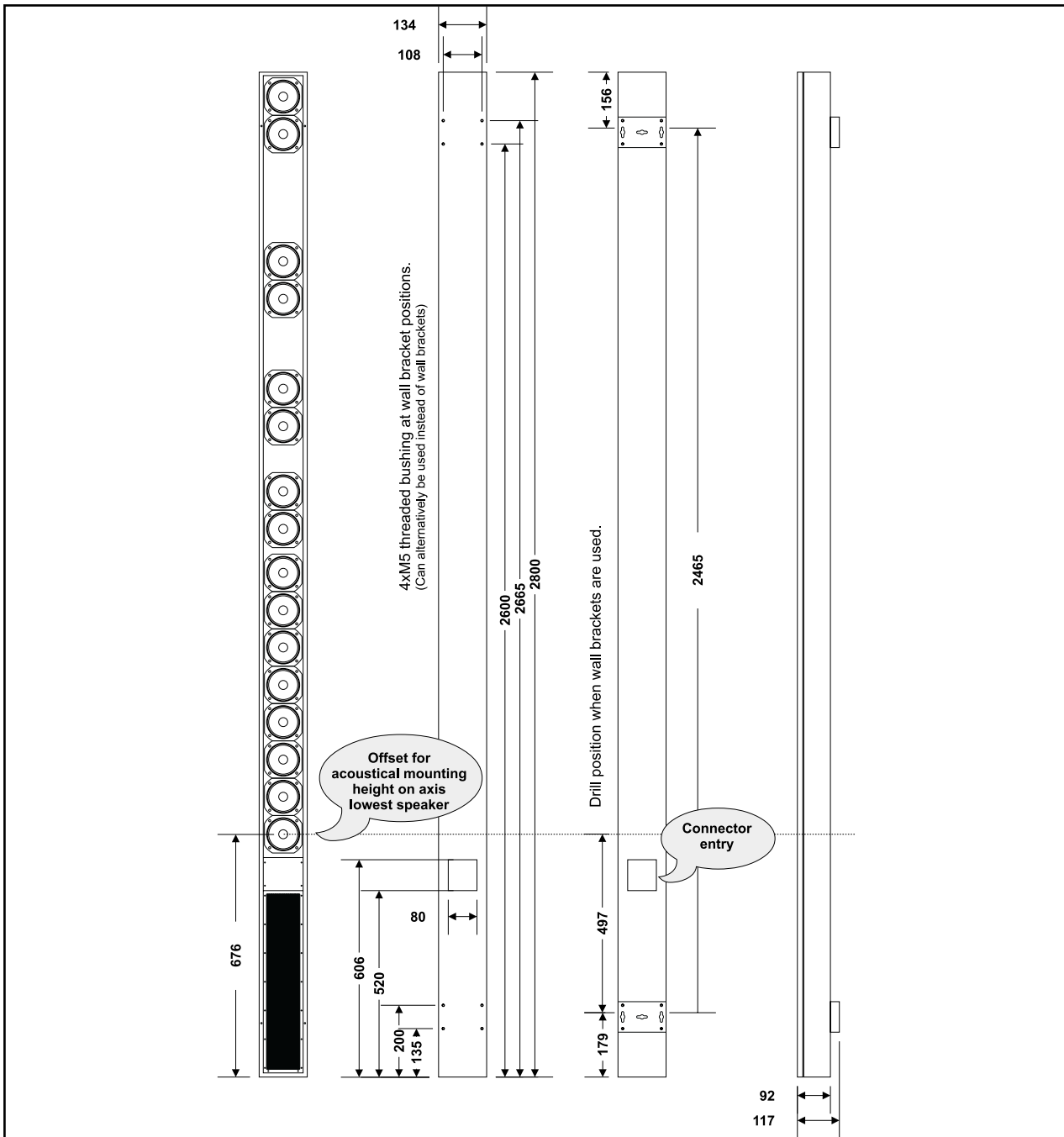

Fig 7 LBC 3253/00 Intellivox-2c dimensions, all measures in mm

columns can differ substantially from the 2c model. Mechanical drawings of the other models can be found in chapter 3.5 or in the respected datasheet.

Fig 7 - The LBC 3253/00 dimensions are shown, including the vertical spacing between the upper and the lower bracket as well as the vertical offset of the acoustical reference.

2.5.3 Mounting procedure.

A short general mounting procedure is described, the actual procedure may differ slightly depending on the actual circumstances and the chosen mounting method. It is assumed that the cabling is already prepared and all connectors are fitted as described in chapter 2.3 and 2.4.

The recommended procedure is as follows:

1. Use plugs in combination with hexagon head screws, this allows the use of a flat key that fits behind the bracket to fasten the screws. Select a type with a maximum head size not exceeding 11.5 mm (0.45").
2. Drill the holes for attachment of the brackets into the wall. It is advised to make use of the slotted holes (two for each bracket, refer to Fig 6) for standard vertical mounting of the column.
3. Insert the plugs and screws into the holes. It should be possible to slide the bracket over the heads. Check this with a bracket before mounting it to the column).
4. Check if the chosen mounting holes ensure that the final position of the column will be in the vertical angle that is specified (which is usually exactly perpendicular to the listening area). Use extra spacers if necessary.
5. Remove the front grill(s) of the Intellivox before mounting the unit and remove the protection foam. This can be accomplished by gently lifting the grill at the positions of the 'snap-in' fittings which hold the grill.
6. Remove the cover of the connector compartment. Make sure the panel is not interchanged with the panel of another unit, because this will also exchange the external serial numbers.
7. Lift the column and slide the brackets over the heads of the screws. Make sure all cabling is fitted through the connector compartment and accessible from the front side.
8. Firmly fasten the screws which secure the brackets to the wall.
9. Re-check if the column is in an exact perpendicular position or in the vertical angle that is specified.
10. Insert the connectors and reassemble the connector compartment cover and the grill(s).

3. Appendix.

3.1 Reference part list.

Connectors for external wiring.

Terminal	Description	Manufacturer	Manufacturer code
RS-485	Wago cage clamp connector 5 pin female 5 mm pitch	WAGO	231-105/026-000
Audio input	Wago cage clamp connector 6 pin female 5 mm pitch	WAGO	231-106/026-000
Failure, Fan, Ambient SPL and Temperature	Wago cage clamp connector 5 pin male 5 mm pitch	WAGO	231-605

Table 3 Intellivox external connectors details.

Other installation related accessories.

Description	Type Number
Intellivox swivel bracket 90°	LBC 3270/00
Intellivox swivel bracket 45°	LBC 3271/00
Ambient mic. and temperature sensor	LBC 3262/00

Table 4 Specific installation related accessories.

Other network related accessories.

Description	Type Number
Program set (Adapter cable+RS-232 to RS-485 adapter+ WinControl CD-Rom)	LBC 3260/00

Table 5 Specific network related accessories

3.2 Grounding strategy.

The ground (GND) terminals on the electronics module serve different purposes.

1. **Safety.** The GND terminal located at the mains IEC connector provides a direct low impedance path from the metal parts of the chassis to ground. In conjunction with a proper designed mains distribution network, this offers extra safety in situations where the standard class 2 insulation is not sufficient (fire, moisture etc.). Always connect the IEC ground terminal.

2. **Reduction of RF emission.** Although the Intellivox electronics module is well shielded and external connections are de-coupled to prevent RF emission from the internal high speed digital circuits, this protection will not work properly when the chassis has no solid ground reference.
3. **Immunity.** The GND terminal shorts currents which are induced by (RF) fields in the signal cables effectively to chassis-ground, provided that the cable shield is of sufficiently low impedance.

To make things even more complex, the RS-485 terminal of the chassis also has a DGND pin, while the ambient SPL/temperature terminal has both GND and AGND pins.

The pins labeled GND are connected directly to the chassis.

The RS-485 DGND pin is not a ground pin, but serves as a reference for the RS-485 AB and YZ wires. Although the DGND pin should be connected to the shielding of the RS-485 cable (when in use), DGND (and ABYZ) has no relation to GND except for the fact that the voltage between DGND and GND is clamped to a maximum voltage of 50 V for reasons of safety and immunity. In an installation with a connected network, the RS-485 cable shield must be grounded at some central position.

- DGND should not be connected to any other ground pin (GND or AGND) on the chassis.

The AGND pin serves as a reference for the SPL and temperature measuring input circuitry. To keep this ground signal as clean as possible, the AGND wires together with the MIC and the NTC signal should be run through a shielded cable. The shield should be connected to the GND pin of this terminal block.

- AGND should not be connected to any other ground pin (GND or DGND) on the chassis.

- Because safety is a very important issue, the safety ground pin of the IEC mains connector should always be connected to a low impedance ground network.

If the standard solution is chosen to be connected the audio (line level) inputs the grounding situation is according to Fig 9.

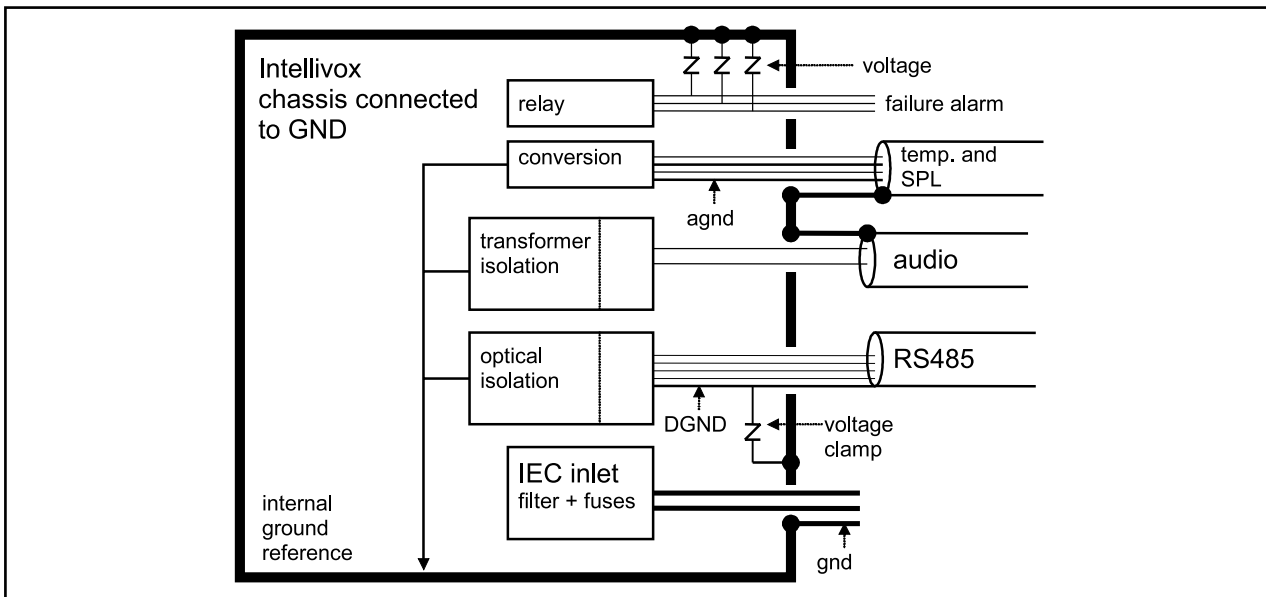

Fig 8 Ground configuration of the Intellivox chassis.

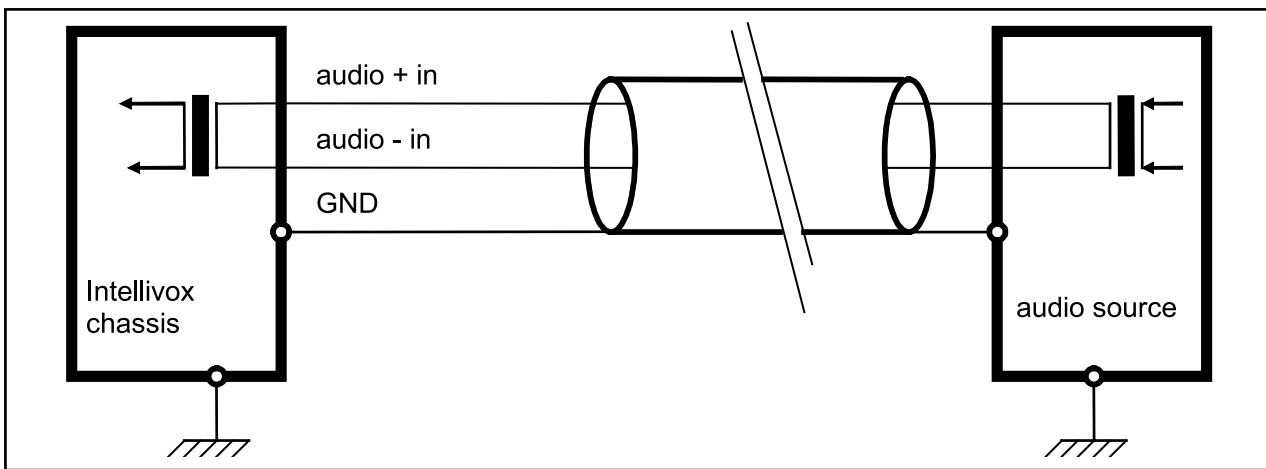

Fig 9 Standard grounding configuration

Although in terms of safety and immunity this is the most preferable set up, an unwanted ground loop is created which can cause audible noise or hum. The appearance of this effect is strongly depending on the cable routing, the design of the grounding scheme and the existence of local magnetic fields (caused by power transformers, railway chopper supplies etc.). If a ground loop occurs, the most straight forward solution to the problem is to interrupt the ground path from the shielding of the audio signal wiring. This situation is shown in Fig 10.

The audio input transformers feature a very high Common Mode Rejection Ratio (CMRR), this means that an interfering signal which is coupled onto both the audio + and - signal wires is strongly rejected compared to the differential audio signal. Unfortunately, this high CMRR is only achieved at low frequencies (<100 Hz) and deteriorates for higher frequencies. In order to restore the original grounding configuration for the HF part of the spectrum, it is good a practice to connect a 100 nF capacitor between the shielding of the audio cable and the GND pin of the terminal block (see Fig 11).

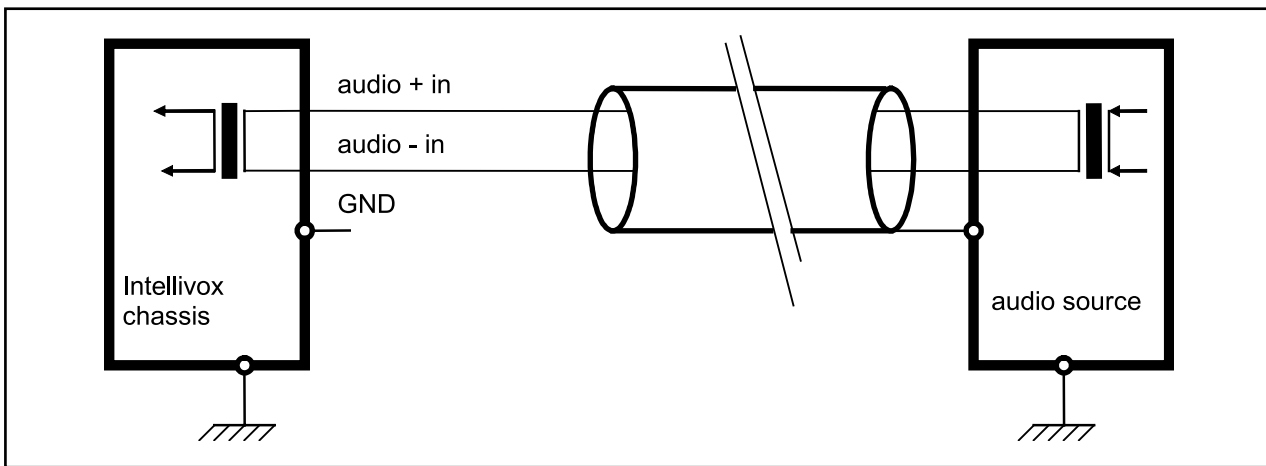

Fig 10 Grounding configuration with totally decoupled audio ground

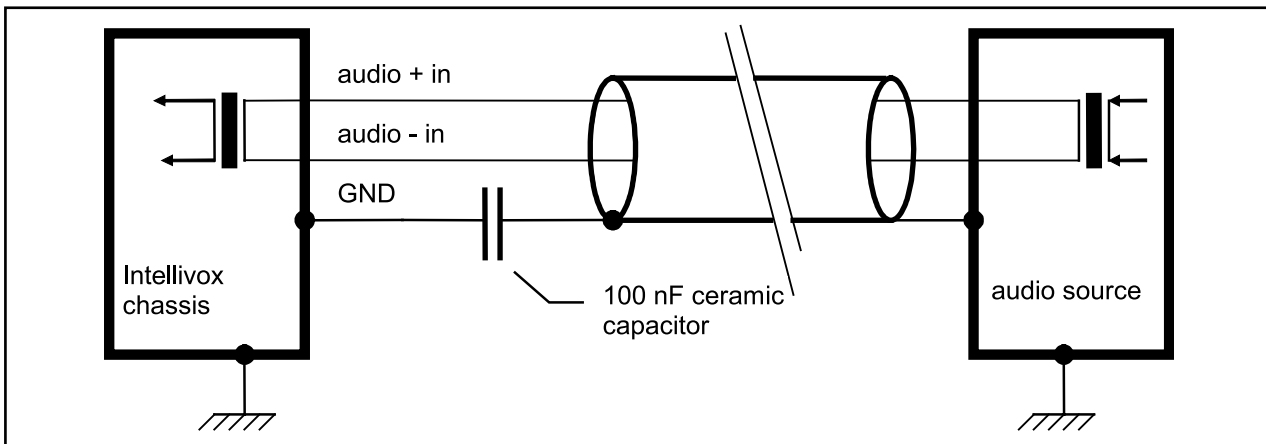

Fig 11 Grounding configuration with low frequency decoupled audio ground

In order to restore the galvanic safety path of the signal wiring up to a certain level, it is possible to connect a 100 OHMS 1W resistor parallel with the 100nF capacitor. The isolation of the low frequency ground loop is partly canceled by this resistor, but the reduction of the induced noise can still be sufficient while at the same time some of the benefits of the original concept are restored. A diagram of this solution is shown in Fig 12.

The method described is also well suited for installations with multiple distributed units on one signal source. If only one chassis is connected, interruption of the loop near the signal source is theoretically a better option, although this method can cause problems if the output of the audio source is not equipped with a transformer (electronically differential output). Due to the capacitive coupling of the (remote grounded) shield, it is possible that a common mode

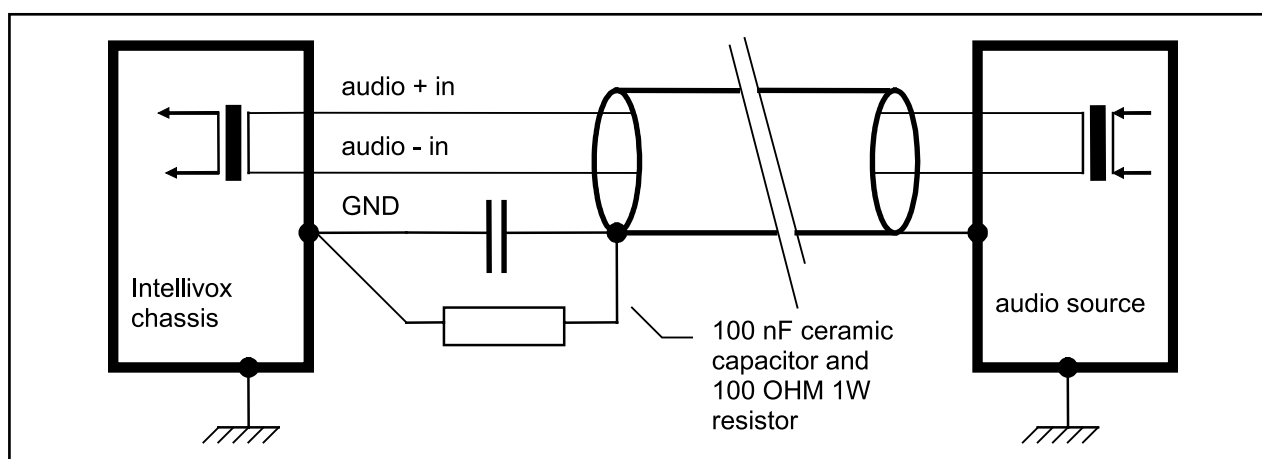

Fig 12 Ground configuration with audio ground partly decoupled for low frequencies

General strategy

The best approach is to interrupt the ground loop just far enough to get rid of the disturbing effects of it. Therefore it is advised to start with the full grounded configuration (Fig 9), if this causes problems try 100 OHMS // 100nF (Fig 12), next leave 100 OHM off (Fig 11) and the final solution might have to be the most rigorous method (Fig 10) which will introduce the danger of trading the hum for RFI problems.

For longer cable runs (> 50m)

Use low output impedance balanced signal sources, preferably transformer balanced. The CMRR for higher frequencies will be heavily degraded if the impedance with respect to ground of both + and - signal lines is not equal (as with unbalanced outputs). Degraded CMRR can also be caused by poor quality cable due to asymmetrical capacitive properties of the core.

interference signal is injected into the output terminals of the source that may cause misbehavior of the electrical driver circuit.

In case the chassis is connected to a 100 V or 70 V distributed system, no ground loop can occur. The configuration resembles the total decoupled ground configuration in Fig 10. To adapt the input transformer to the much higher 70 V / 100 V signal level, the input is internally attenuated by a differential mode divider network. This means that the common mode sensitivity of the attenuated 70 V / 100 V input is not different from the 0 dB input. If any problems occur caused by common mode induced RFI, a possible solution is to reduce the common mode impedance for high frequencies by adding two 100 pF capacitors as shown in Fig 13. For optimum CMRR the values of the capacitors should be matched as close as possible. An optional ferrite clamp can be used in combination with the capacitors to enhance the performance of the filter.

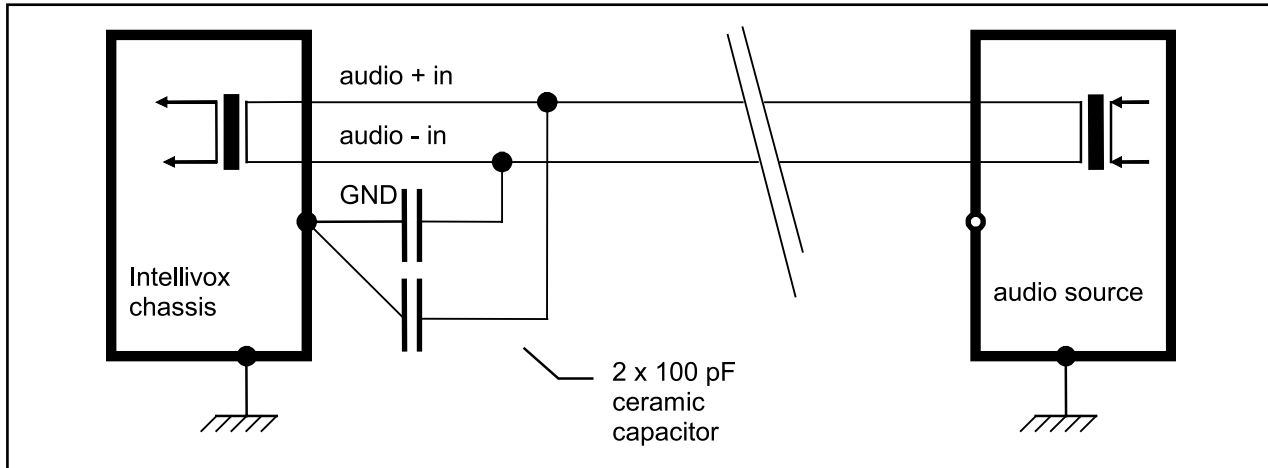

Fig 13 Optional high frequency decoupling for 70 V / 100 V systems.

Conclusion:

Because the Intellivox can be a part of a complex installation it is impossible to prescribe a fixed grounding strategy that will perform best in all situations. Safety, immunity and reduction of emission are very important issues that should always determine the ground configuration that is applied.

This appendix describes some methods to eliminate possible noise caused by ground loops without sacrificing safety or emission, although a minor degradation of the immunity can be expected which is depending on the configuration chosen.

3.3 Some notes on the RS-485 network interface.

In order to integrate the unit in a surveillance and control network a full duplex RS-485 terminal is incorporated. The RS-485 standard is chosen for the ability of driving long cables, the simplicity of the network topology and high immunity to external electromagnetic fields which results in low error rates. A disadvantage of the full duplex set up is the required 5 wire interface. The RS-485 interface on the unit exists of a differential input port (AB), a differential output port (YZ) and a dedicated network ground terminal (DGND).

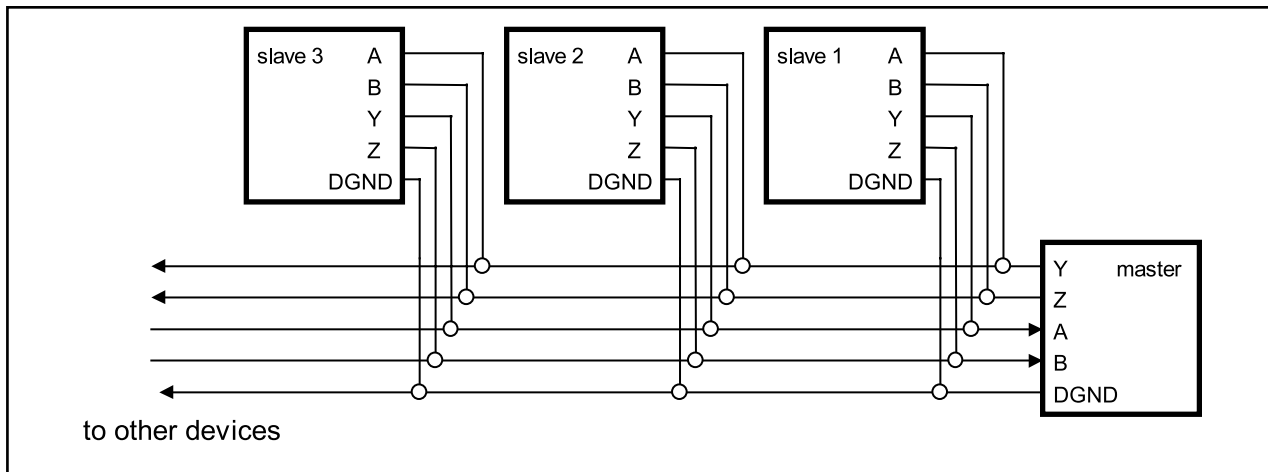

Fig 14 Structure of the RS-485 network

Network configuration.

A network is composed of one master device and one or more slave devices. A master device can exist of a PC running the RS-485 network WinControl software and a RS-232 to RS-485 converter. All slave devices are wired in parallel, the master device is connected with the AB and YZ terminals interchanged (see Fig 14).

Because all slave devices share the same bus, the outputs (YZ) of these units are only enabled during transmission of data from the unit to the master. The implemented network protocol sets the output of all other units in a high impedance state during this period to prevent conflicts. For this reason each device has its own network address.

The official RS-485 standard limits the amount of nodes to 32. This is mainly because of the low resulting network impedance when all units are connected. The chassis is equipped with a new generation high impedance RS-485 transceivers, increasing the maximum node count from 32 to 256.

The RS-485 network protocol limits the amount of slave addresses to 126 and allows one master device.

Cable length

The maximum cable length is heavily depending on the cable characteristics and the baud rate. The RS-485 network baud-rate is 19200 bits/s which is relatively low for the RS-485 transmission path. Using low capacity low resistance cable the maximum length specified for safe transmission is 1500 m. If the distance is significantly longer, a network repeater will be needed.

Cable termination

According to the official RS-485 standard, the network should be terminated with 120 OHM resistors at both ends of each pair, while the length of the stub lines should not exceed 7 m. The RS-485 transceivers, which are implemented in the chassis, are slew rate limited which minimizes reflections from open cable lengths. This fact, in combination with the relative low baud-rate, makes the network very tolerant to stub lengths or improper termination.

In practice, termination resistors will only be needed in combination with large cable lengths and large stub lengths.

Cable type

The required cable type for implementation of the network is twin twisted cable of which both twisted pairs are individually shielded.

An example of a preferred extended range cable type is:

Type:	BELDEN 'Datalene' series nr. 9729 2-pairs
Characteristic impedance :	100 Ohms
Core to core capacity :	41 pF/m
Core to shield capacity :	72.5 pF/m
DC resistance core :	78.7 Ohms/km.
DC resistance shield :	59.1 Ohms/km.

This cable has a foil shielding with drain wire and a tinned litze core.

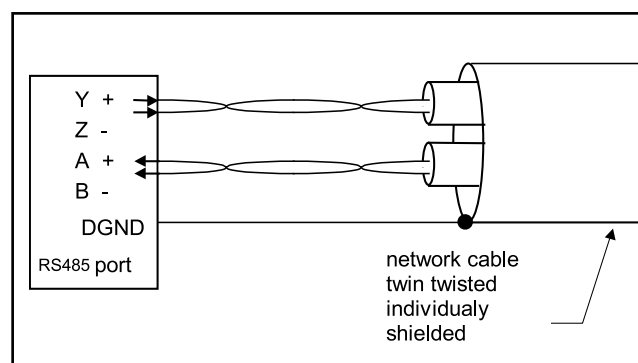

Fig 15 Connection of twin twisted network cable to the unit

Alternative cable types are

- : Belden 1902A or equivalent.
- : BICC Brand-Rex H9002 AWM 2493

Master device

As mentioned before the RS-485 network concept needs one master device. This master device (network controller) is composed of a PC running WinControl and a RS-232 to RS-485 adapter connected to the RS-232 port of the PC. Detailed information about the WinControl program can be found in the related help file.

The RS-232 to RS-485 adapter is a small 9-pin sub-D device which can be connected to one of the computer's serial COM ports. In the normal case the adapter is directly powered from the RS-232 terminal of the PC. The RS-232 to RS-485 adapter is not galvanically isolated. The adapter is intended for network connections during installation, maintenance or operation whenever control over specific process parameters is needed. In conjunction with the adapter a dedicated cable is needed with a 9-pin sub-D female connector and a WAGO cage clamp connector (see Table 6 to Table 8).

Master (PC)	9p sub-d	Slave (unit)	5p cage clamp	5p XLR
RS-485 Y (+send)	3	RS-485 A (+ receive)	1	5
RS-485 Z (-send)	8	RS-485 B (- receive)	2	4
RS-485 B (-receive)	2	RS-485 Z (- send)	3	3
RS-485 B (+receive)	7	RS-485 Y (+send)	4	2
Ground	1,4,5,6	DGND	5	1
External +9V DC (optional)	9	-	-	-

Table 6 RS-485 connection cable for use with RS-232 to RS-485 adapter.

RS-232 description	RS-232 pin #
NC	1
RX	2
TX	3
DTR	4
GND	5
DSR	6
RTS	7
CTS	8
+9 V	9

Table 7 RS-232 pin description of the RS-232 to RS-485 adapter.

RS-485 description	RS-485 pin #
GND	1
RS-485 B (-receive)	2
RS-485 Y (+send)	3
GND	4
GND	5
GND	6
RS-485 B (+receive)	7
RS-485 Z (-send)	8
+9 V DC	9

Table 8 RS-485 pin description of the RS-232 to RS-485 adapter

Notes for type RS-232 to RS-485 adapter:

- Both ends of the RS-232 to RS-485 connector have the same 9p female sub-d connector. Be careful to install it in the proper way.
- The +9 V (pin 9) at the RS-232 side of the adapter should be connected to an external + 9 V / 50 mA DC power supply in case the power delivered by the PC (RTS or DTR) is insufficient. This might be the case with large cable lengths.
- RTS and CTS are internally connected, DTR and DSR are also internally connected.

3.4 LBC 3262/00 Ambient SPL and temperature sensor.

Description.

The Intellivox electronics module is equipped with an external terminal (labeled ambient noise / temp) to connect a sensor for the ambient SPL and temperature measurement. Although the unit is able to operate normally without the sensor, it is needed when the auto gain function or the frost protection is used.

The temperature is measured by a NTC resistor. By means of a software correction table the non-linear resistance characteristics of the NTC are compensated and converted into a degree scale. The SPL is measured by an electret microphone, rectified and converted to a dB scale. The microphone is powered by the amplifier module through the connector.

Location of the sensor.

Both NTC and microphone are mounted in a single compact enclosure which can be located at a certain distance from the column. In most situations the best location is determined by the microphone (see also chapter 2.2). The auto gain will only work correctly if the diffuse ambient noise level is used as a reference. This means that the microphone should be kept away from direct sound sources such as talking people, outlets of the air conditioning system or other loudspeakers.

The implemented software protocol freezes the volume setting when an audio signal is present in order to prevent 'hunting' of the column's gain setting caused by its own radiated acoustical energy.

- Although the circuit of the combined sensor is not complex, the specific characteristics are very important for a correct interpretation of the measured values. For this reason it is strongly advised to use the appropriate factory tested sensor (see chapter 3.1 for order codes).

Wiring.

For reasons of RFI immunity and optimum noise characteristics two different ground terminals are implemented. The terminal labeled GND is connected directly to the chassis, while the terminals labeled AGND are reference ground terminals.

- GND and AGND should be kept apart under all circumstances!

For correct wiring an asymmetrical shielded 2 way cable with overall shield is advised. Alternatively the twin twisted cable, which is also optionally in use for the RS-485 network interface, can be used. Reference source not found. (next page) show the correct wiring diagram for both cables.

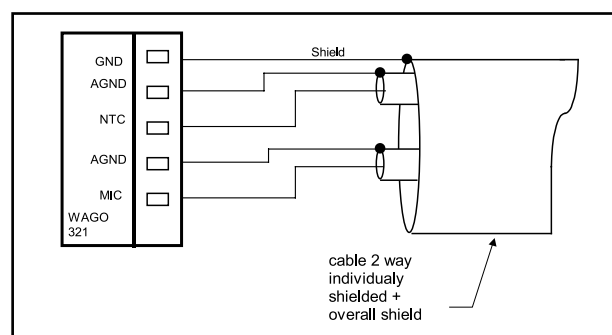

Fig 16 Wiring configuration using asymmetrical cable type

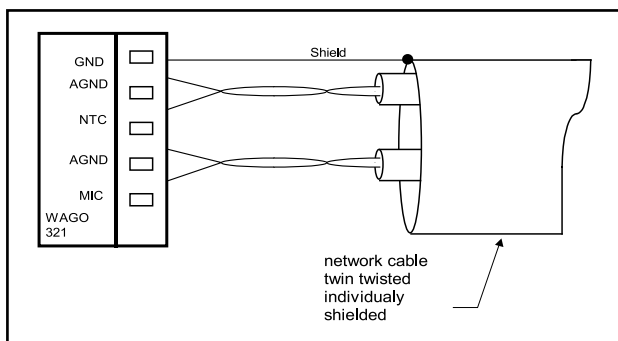

Fig 17 Wiring configuration using RS-485 network cable type.

Ambient SPL and temperature sensor connections.

Figure 18 and 19 show the wiring configurations for the sensor with the two cable types.

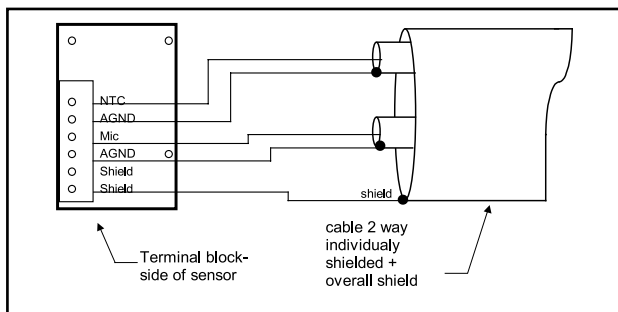

Fig 18 Wiring configuration at the sensor using asymmetrical cable type

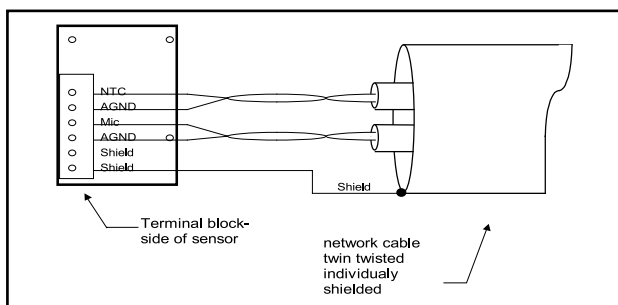

Fig 19 Wiring configuration at the sensor using RS-485 network cable type

3.5 Intellivox dimensions of the different models.

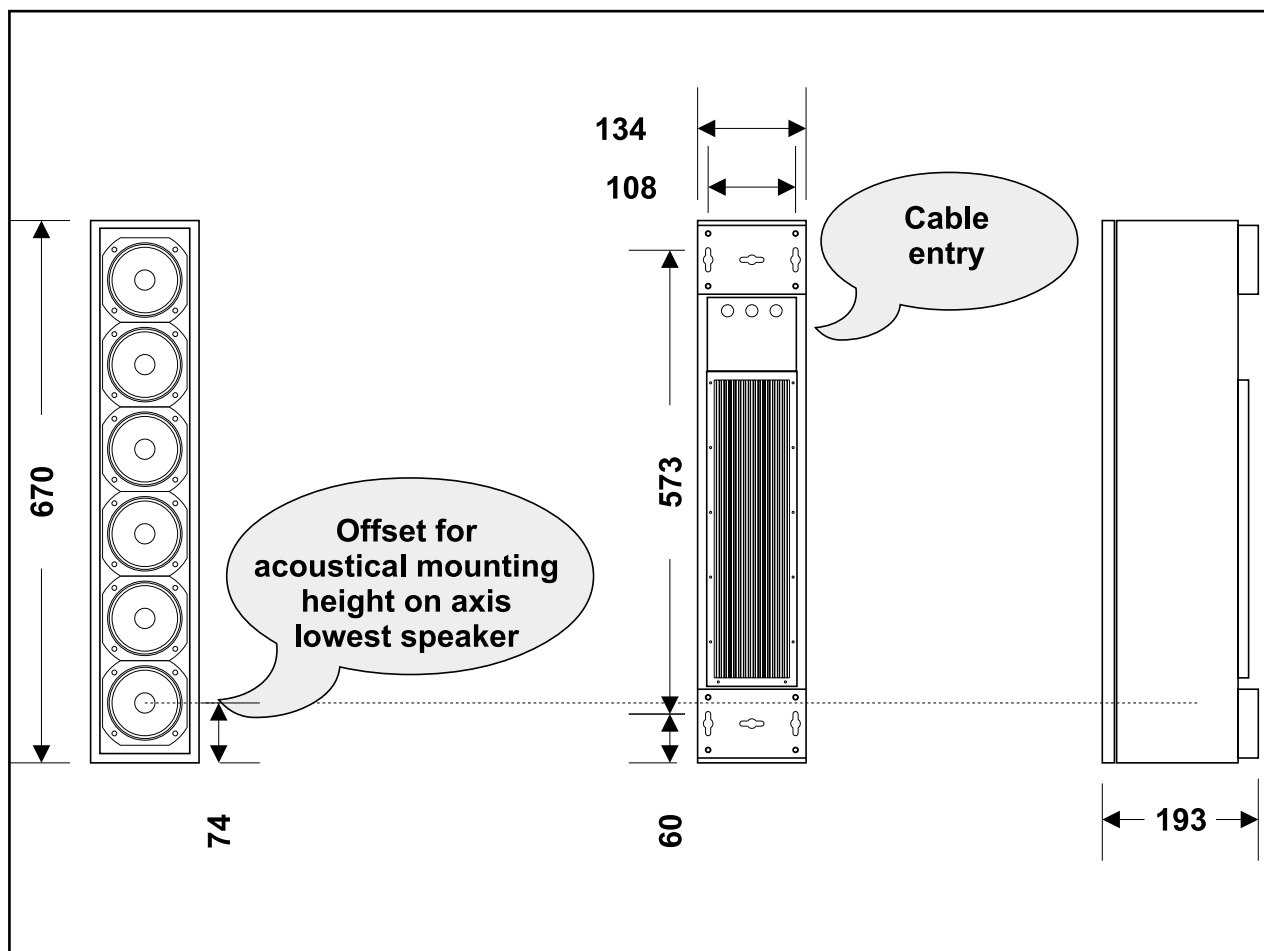

Fig 20 LBC 3251/00 Intellivox-1b dimensions, all measures in mm.

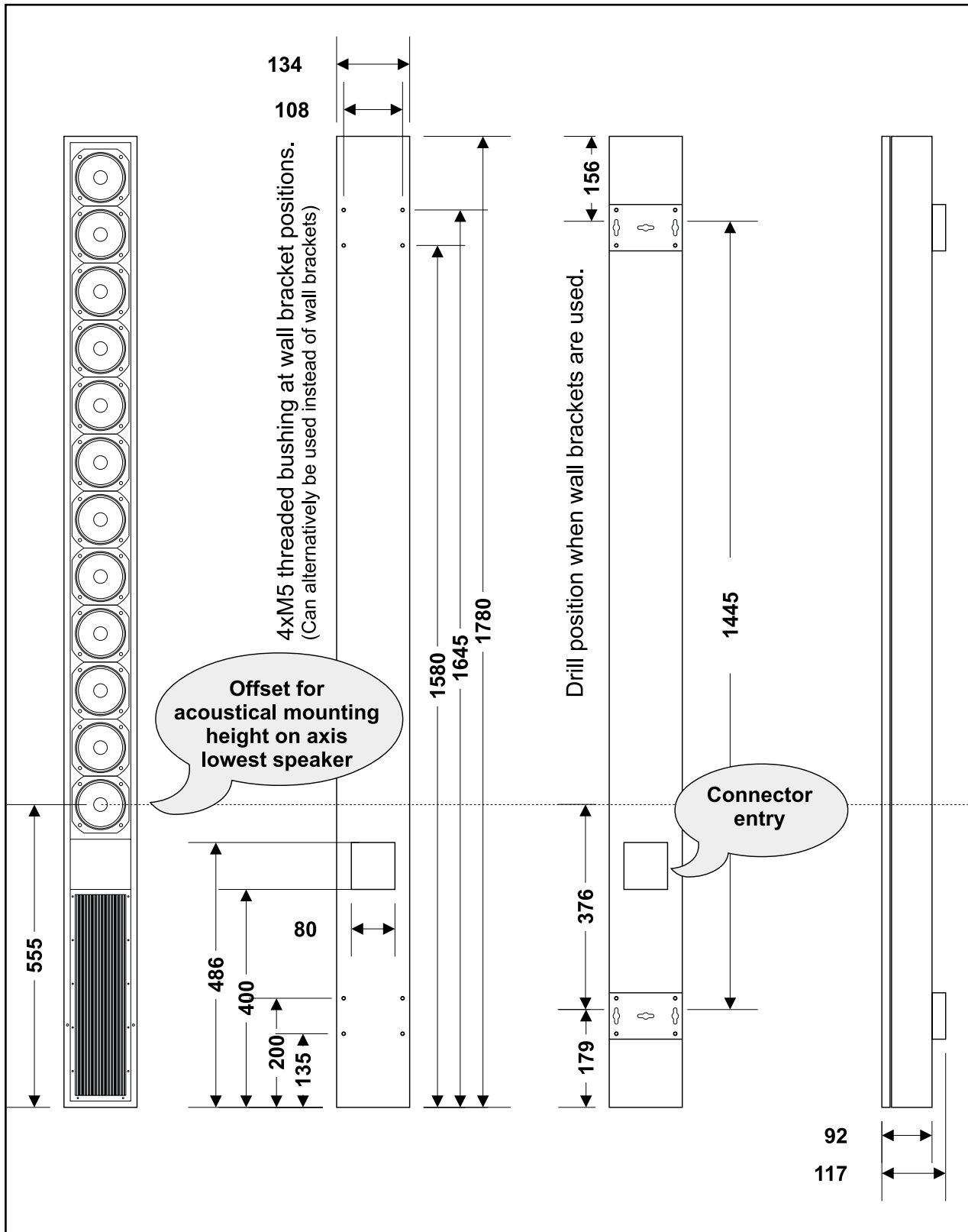

Fig 21 LBC 3252/00 Intellivox-2b dimensions, all measures in mm

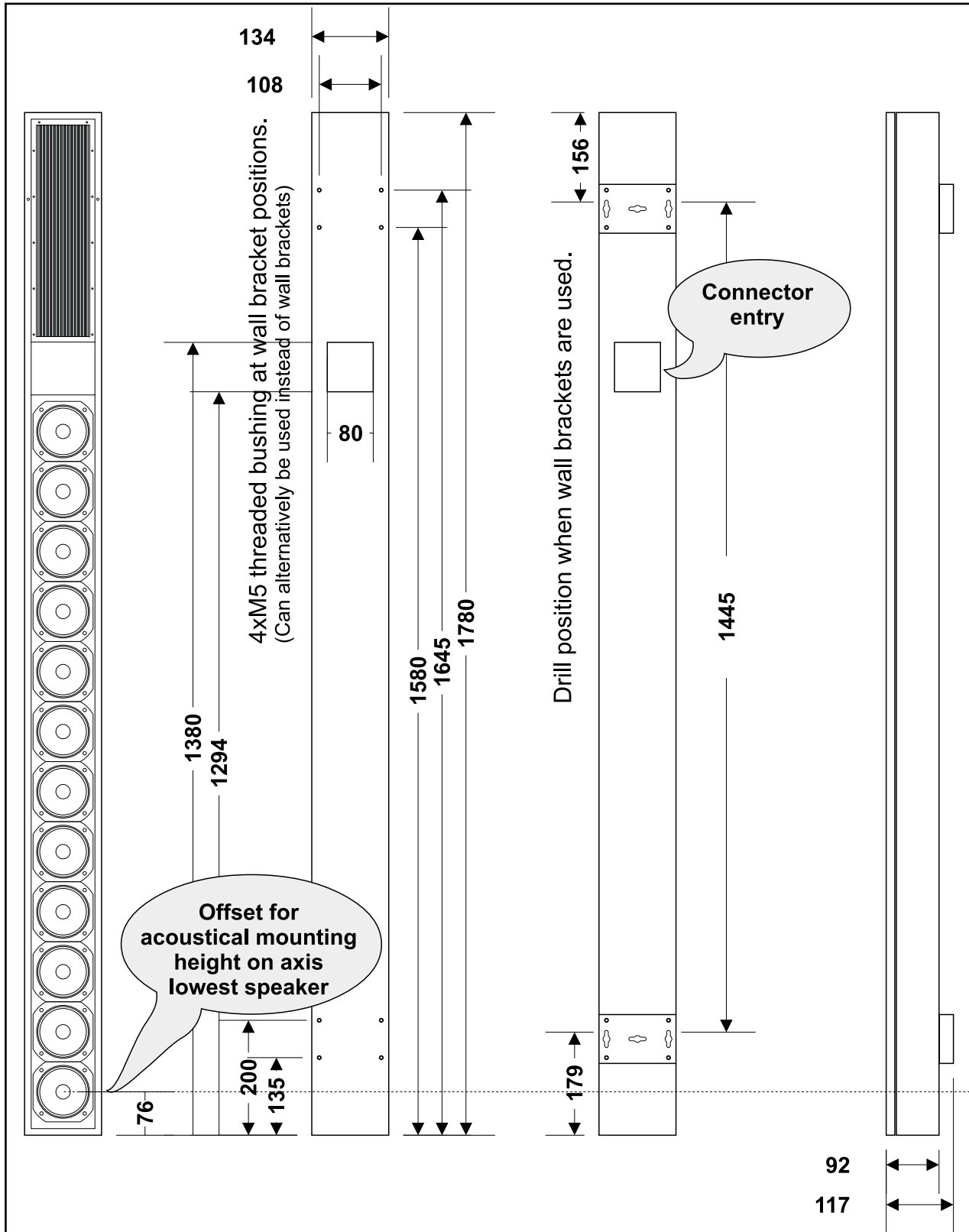

Fig 22 LBC 3252/10 Intellivox-2b dimensions, all measures in mm

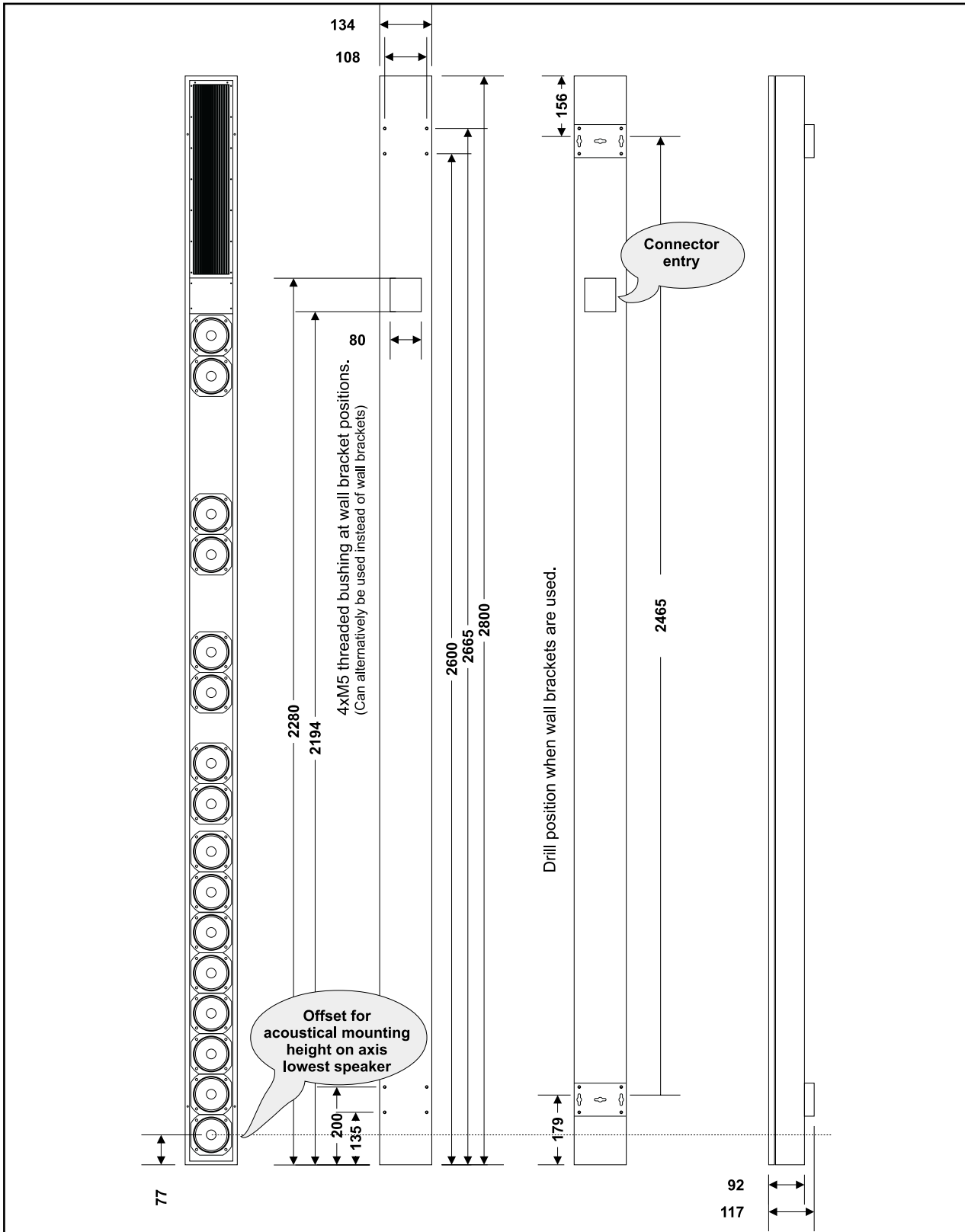

Fig 24 LBC 3253/10 Intellivox-2c dimensions, all measures in mm

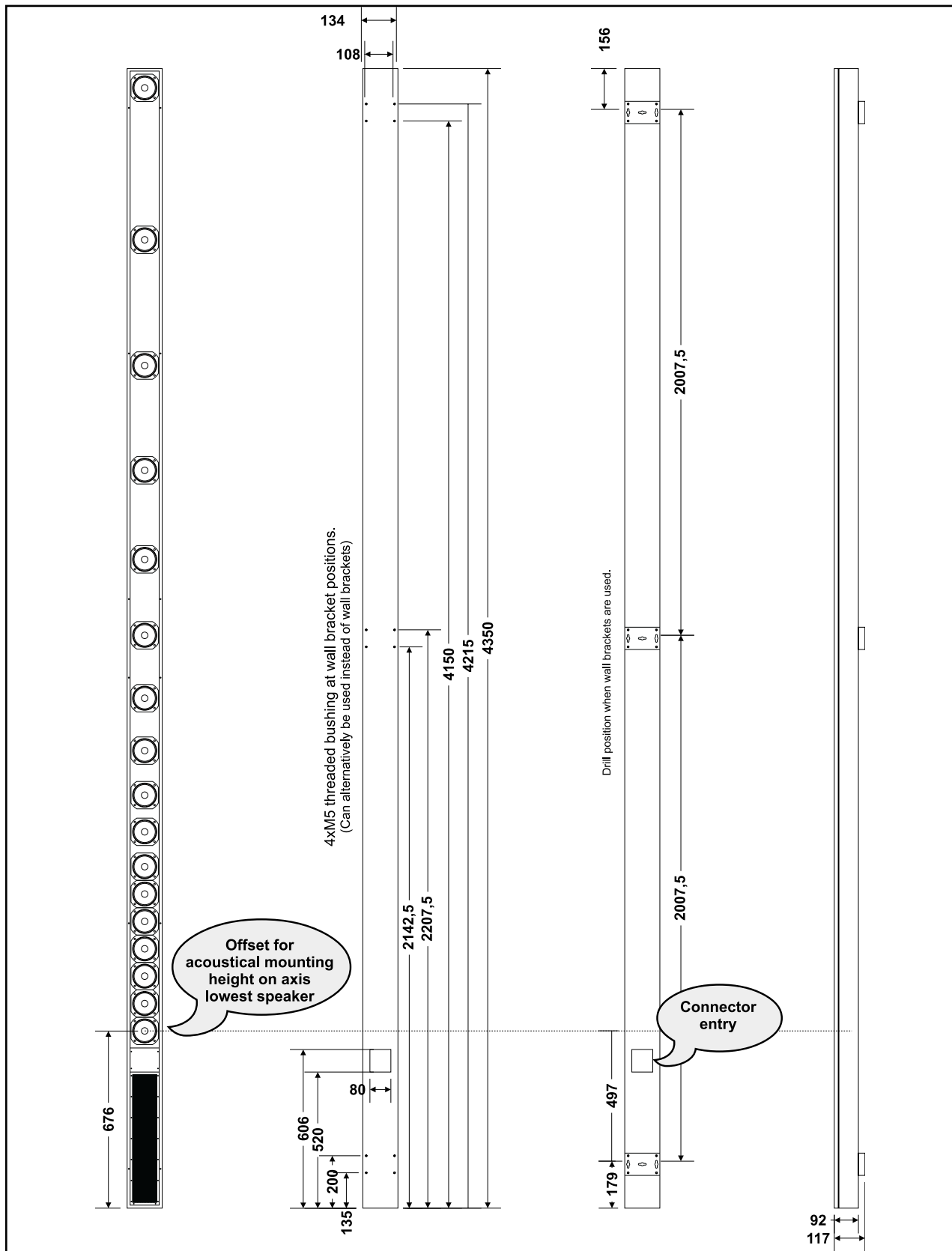

Fig 25 LBC 3254/00 Intellivox-4c dimensions, all measures in mm.

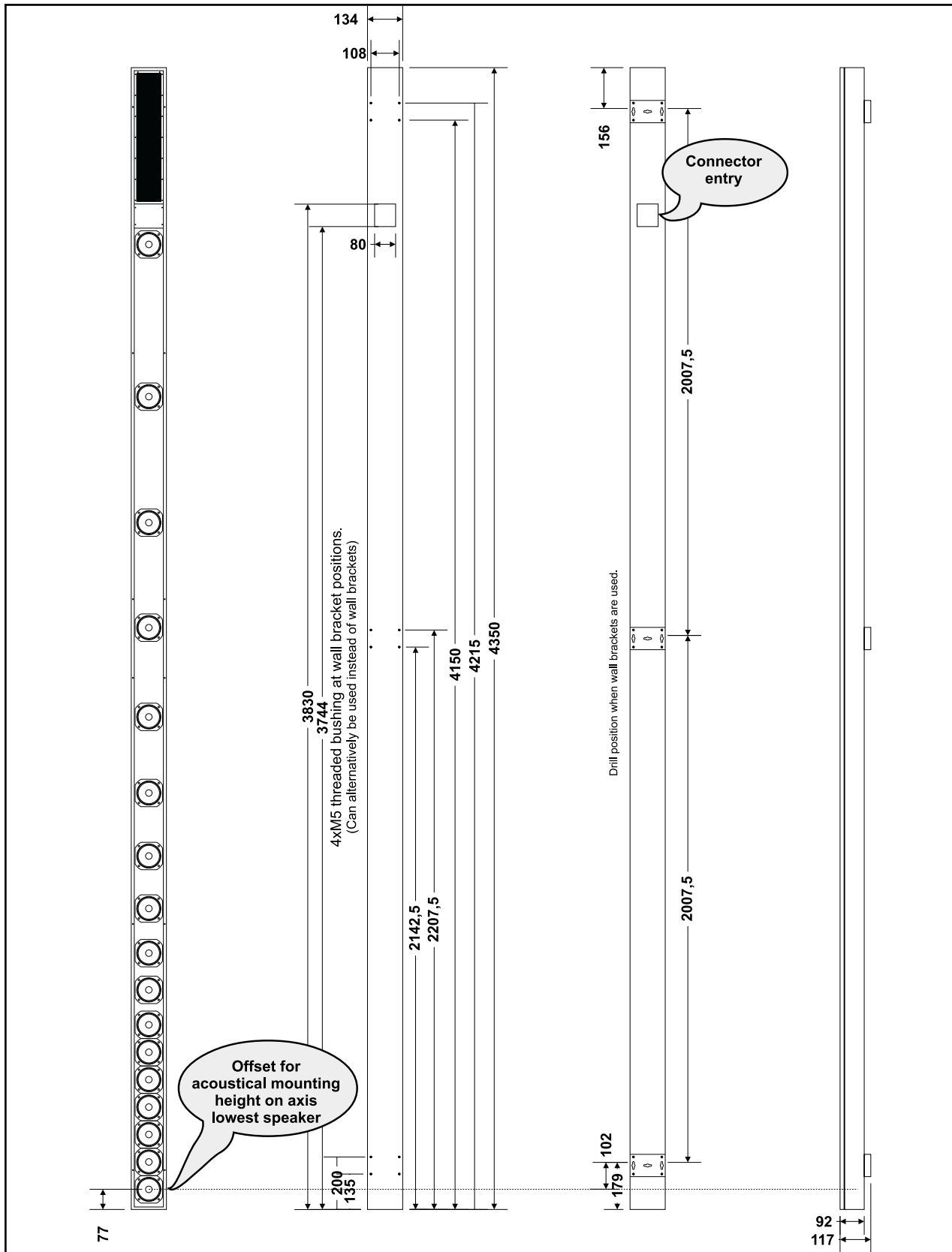

Fig 26 LBC 3254/10 Intellivox-4c dimensions, all measures in mm.

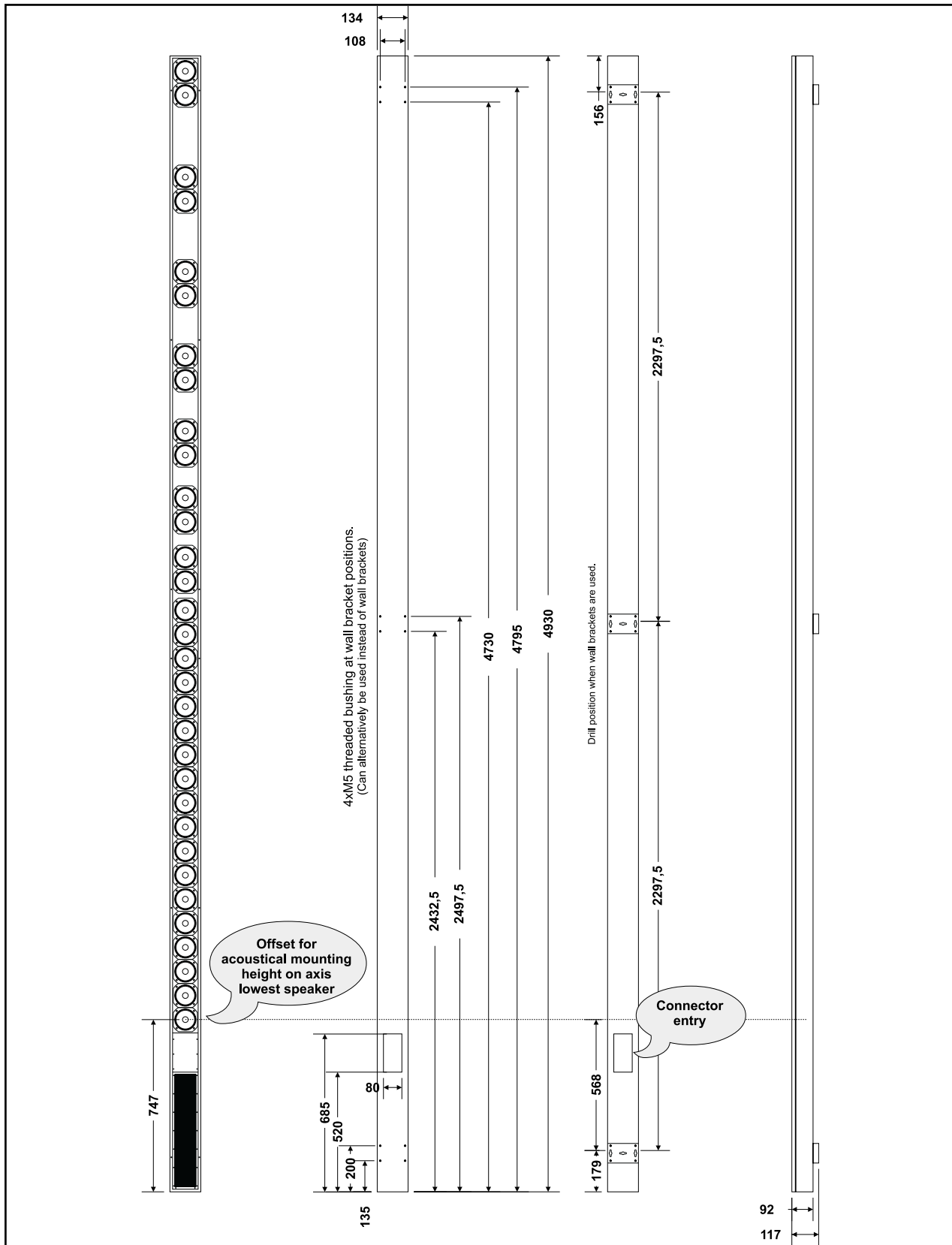

Fig 27 LBC 3256/00 Intellivox-6c dimensions, all measures in mm

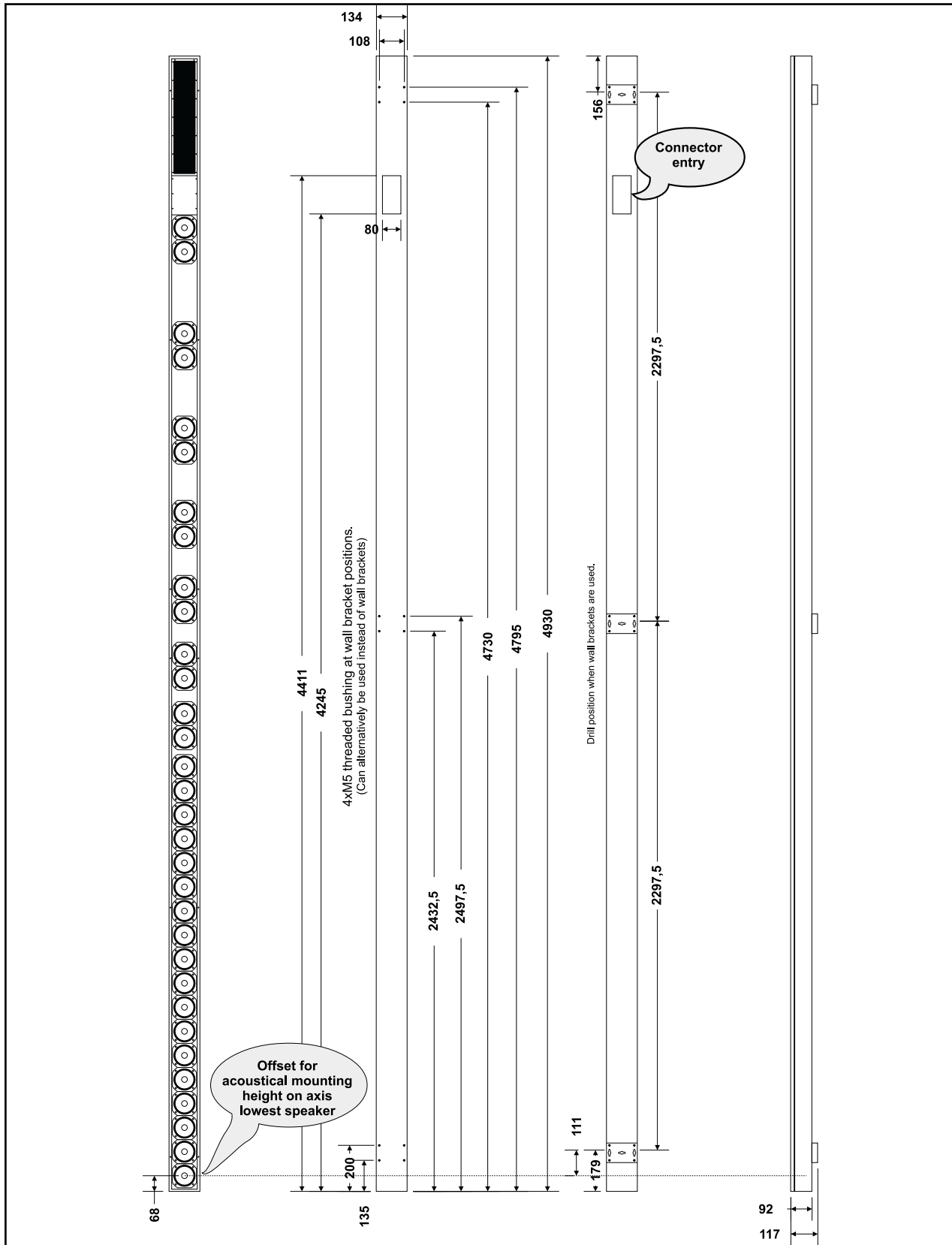

Fig 28 LBC 3256/10 Intellivox-6c dimensions, all measures in mm

Robert Bosch GmbH
Geschäftsbereich
Postfach 10 60 50
70049 Stuttgart
Telefax (07 11) 8 11-12 34
www.bosch.de/k

Bosch Security Systems B.V.
P.O. Box 80002
5600 JB Eindhoven
The Netherlands
Tele +31 40 27 80000
www.boschsecuritysystems.com

© 2003 Bosch Security Systems GmbH
9922 141 50511en

BOSCH